

Vehicle cleaning with brilliant results.

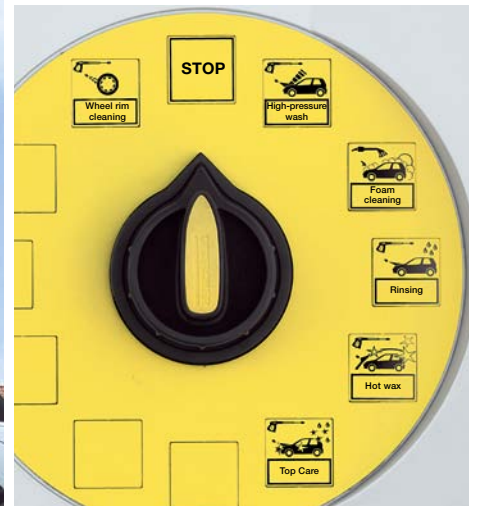



Sophisticated system solutions for your profit.

Power, reliability and efficiency are always at the forefront of successful, profitable coin-op washes. The perfectly balanced system components from Kärcher always work cost effectively and are profit-oriented. In addition, the system solutions can be adapted to the customer's preferences – a benefit for you and your customers.

Contents

Coin-op car washes	Page	4
Self-service single-bay units	Page	6
Self-service multi-bay systems	Page	7
SB MB	Page	8
SB MU	Page	9
Self-service vacuums	Page	10
Steel structure for self-service washing bays	Page	11
System solutions	Page	12
Technical data	Page	13
Washing bay equipment	Page	14
Cleaning agents	Page	15
cleanpark® franchise system	Page	18

Leave nothing to be desired: Kärcher coin-op car washes.

Customised coin-op car washes from Kärcher are highly versatile and can be adapted to suit your needs and the preferences of your customers without high expenditure. The systems are modular and can be expanded to up to eight stations. This means there is no obstacle left in the way of your company's growth.



1 Self-service single-bay units

Thorough and cost-saving: the self-service single-bay units are perfect as an additional business for service stations or for your company's vehicle fleet.

2 Self-service multi-bay systems

Compact and energy-efficient: the cabinet version contains everything needed for a profitable car wash with up to four bays. Modules are available for up to eight bays.

3 Self-service vacuums

Easy and ergonomic: Kärcher single or two-bay vacuums for cleaning vehicle interiors are easy to use and feature an ergonomically designed suction nozzle for use in difficult-to-reach areas.

4 Steel structure for Kärcher self-service washing bays

Elegant and functional: the steel structure Attica shapes are available with or without design elements. The sophisticated lighting concept extends operating hours.

Big performance in small packages: Kärcher self-service single-bay units.

Kärcher entry-level models impress with low investment costs and are ideal for confined spaces. The ideal solution for newcomers to professional washing or for cleaning vehicle fleets.



1 For complete cleaning: Kärcher coin-op car wash
the complete solution for pre-wash and foam wash in confined spaces.



2 For brushless cleaning: Kärcher HDS-C
Basic model for complete prewash and interim quick wash.

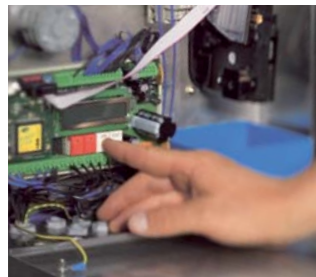

Full control
Display of all relevant operating data at the push of a button.



Durable technology
Water softening systems prevent lime deposits and guarantee the durability of the system.

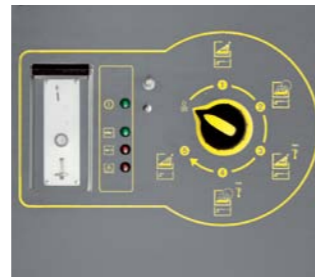

Self-explanatory programmes
Easy and self-explanatory wash programme selection via a control with remaining wash time display.



Versatile equipment
Individual system equipment with high-pressure lance holder, hose reel or pivoting beam.

For every requirement: Kärcher self-service multi-bay systems.

Kärcher offers versatility and the perfect solution for every location: the SB MB for two to four washing bays as skid or cab version and the SB MU for four to eight washing bays as container or component version.

The SB MB versions:

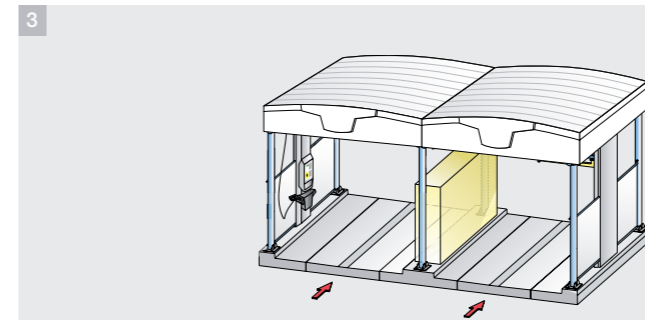
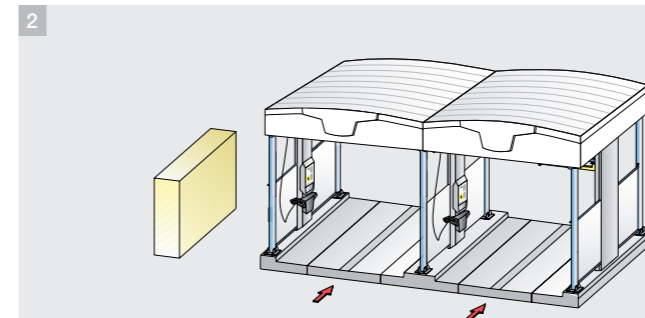
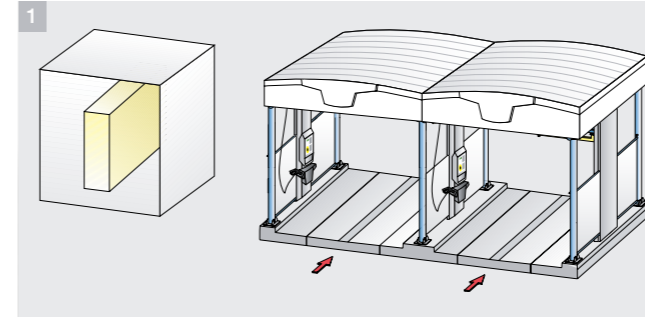

1 Skid version

Pre-assembled frame that can be installed in an on-site technical room.

2 Cab version

Construction outside of the washing bays and simple programme selection using a remote control location.

3 Cab 1 and cab 2 version

The cab 1 version with combination washing tool (brush and high pressure) or the cab 2 version with separate washing tools (separate brush and high-pressure lance) are installed between the washing bays.

The SB MU models:



1 Container version

Ready to use! The equipment can be assembled in a container and just needs to be installed and connected.

2 Component version

The components are delivered and installed in an on-site technical room.

Innovation in confined spaces: Kärcher SB MB.

Simply install, connect and get going: the Kärcher SB MB is ready for use in no time as the equipment is compactly pre-installed in a cabinet at the factory. Precise cleaning agent dosing and advanced technology ensure the durability and efficiency of the system.

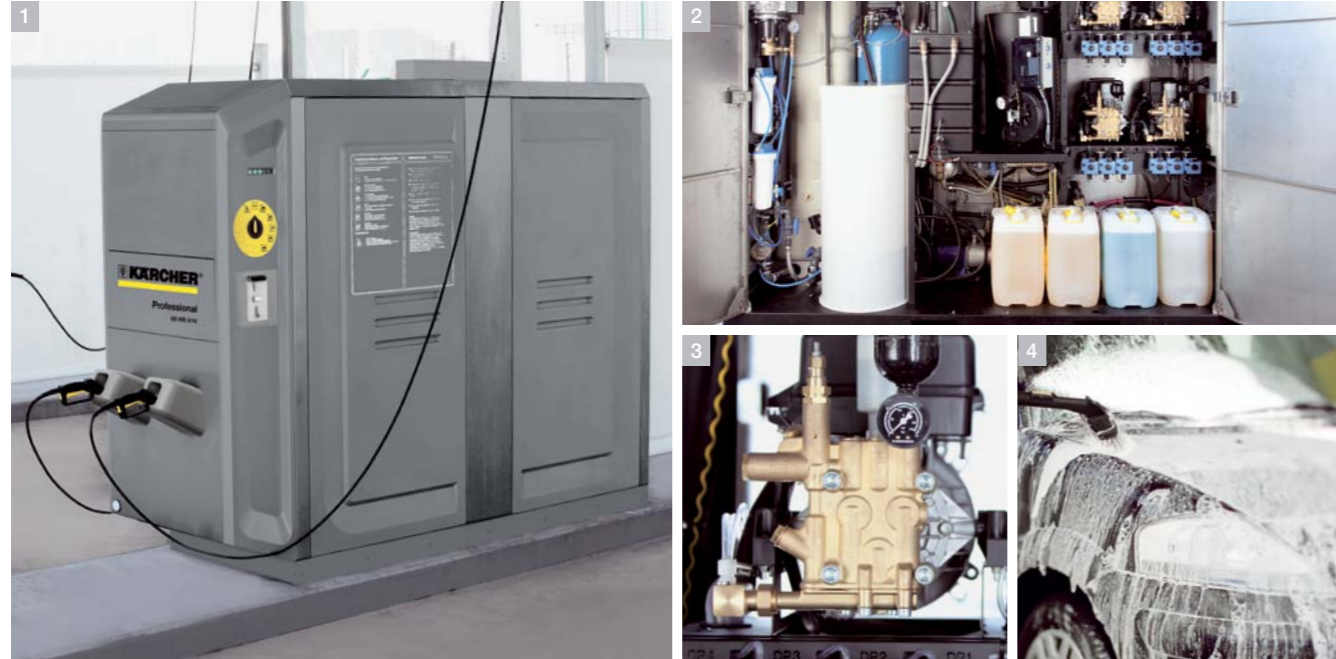

1 Space-saving design

The compact design means that all components fit in a single base cabinet.

2 Easy service

The large front doors with a removable middle bar ensure easy maintenance of the system.

3 Low energy consumption

Water-cooled pumps reduce energy consumption and costs.

4 Reduced water consumption

The use of dry foam reduces water consumption and saves natural resources.

Modular and adaptable: Kärcher SB MU.

The modular design of the Kärcher SB MU allows adaptation of the system to local conditions and offers versatility for wash centres with four to eight washing bays.

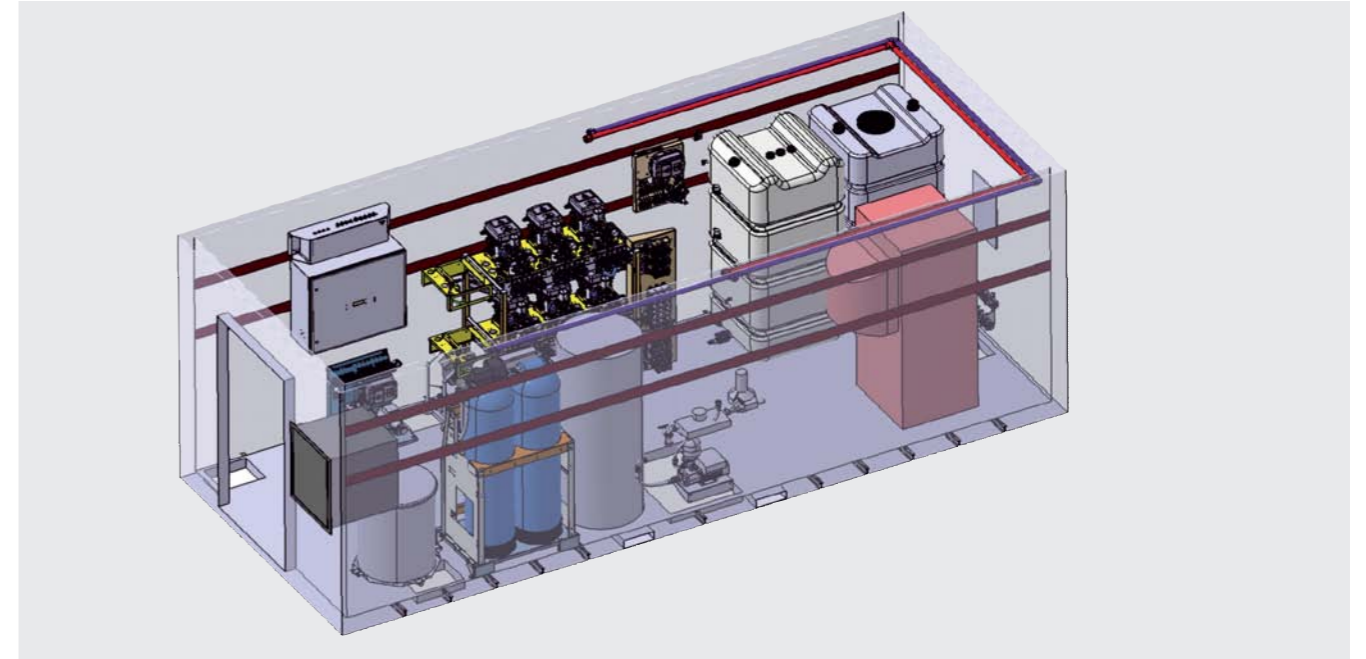

Individual components such as hot water or fresh water generator and a complete range of washing bay accessories can be combined to suit specific requirements. Versatility that pays:

if your company grows, your washing centre can be expanded by up to eight washing bays without great expense.



Secure protection

The two-key system allows the unit to be opened while the coin cassette remains closed.



Flexible programming

Individual programming of up to 11 wash programmes.



Economic cleanliness

Kärcher cleaning agent concentrate reduces consumption and operating costs.



Reliable dosing

Dosing pumps guarantee process reliability and ensure smooth operation during peak periods.



Easy rim cleaning

Rim cleaning takes place with the high-pressure lance. This obviates the need for a separate washing tool.



Durable technology

Water softening systems prevent lime deposits and ensure the durability of the system.

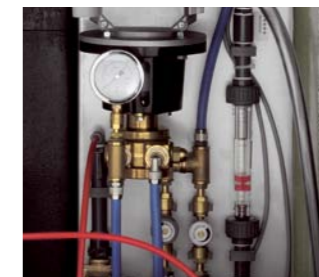

Streak-free shine

Spot-free vehicle drying thanks to integrated osmosis system which dissolves minerals in the water.



Intuitive control

Easy programme selection via control. The remaining time display indicates the remaining wash time.

Maximum performance for the interior: Kärcher self-service vacuums.

Kärcher SB vacuums combine user friendliness and efficiency. All models are versatile, low-maintenance and ensure customer satisfaction.



1 The entry-level model: Kärcher SB V1 Eco
With exceptional filter cleaning technology and an attractive price/performance ratio, the compact SB V1 Eco is the perfect solution for service stations, car dealers, vehicle fleets and car workshops.

2 The classics: Kärcher Mono/Duo self-service vacuums
High cleaning performance and robustness characterise the Mono/Duo self-service vacuums. All models are available in either single- or three-phase current.



Reliable protection
A special device protects the suction hose from rain and dirt.



Constant suction power
With TACT technology, the filter cleans itself, guaranteeing constant suction power.



Individual colours
All vacuums are available in RAL colours or brushed steel.



Variable payment options
Simple self-service payment function with tokens or coins and a digital remaining time display.

Beautifully functional: Kärcher steel structure for self-service washing bays.

The Attica shape of the roof combines beauty with functionality. The steel structure is available with or without design elements, which enables the application of your corporate identity. In addition, the sophisticated lighting concept with integrated feel-good effect serves for customer orientation.



1 Full flexibility
The Kärcher steel structure is the perfect solution for systems with one to eight washing bays.

3 Diverse roof variants
The roof is available as curved acrylic or as trapezoidal sheet steel.

2 Multi-functional unit
Integrated washing tool storage including remote control.

4 Various separating wall materials
The separating walls are available in glass, Trespa or foil and can be individually designed.

Completely satisfied: with Kärcher system solutions.

The efficient and sophisticated system solutions meet every requirement. Whether washing centre, service station or supermarket, you can rely on Kärcher.



1 Comprehensive range of services

Kärcher meets all requirements of a modern car wash centre. Our products range from gantry car washes, coin-op car washes to the practical expansion of existing systems with innovative equipment.

2 Brilliant sales

With high-performance designs, Kärcher ensures increasing sales figures. The systems work reliably, efficiently and are low-maintenance. All in all, a result that can be seen.

3 Numerous advantages

As a leader in quality, Kärcher offers numerous advantages. Competitiveness and the efficient utilisation of parking spaces is an incentive to customers and increases additional business.

At a glance: technical data.

Self-service multi-bay units



	SB MB 5/10	SB MU
Number of washing bays	2-4	48
Working pressure	100 bar/10 MPa	100 bar/10 MPa
Flow rate (per pump)	500 l/h	500 l/h
Hot water temperature	max. 60°C	max. 60°C
Power supply	3~/400 V/50Hz	3~/400 V/50Hz

Self-service single-bay units



	SB Wash 5/10	Additional cabinet*	HDS-C 7/11	HDS-C 9/15	HDS-C 8/15 E
Working pressure	100 bar/10 MPa	-	100 bar/11 MPa	115 bar/15 MPa	115 bar/15 MPa
Water flow rate	500 l/h	-	700 l/h	900 l/h	740 l/h
Temperature (operation)	max. 60°C	-	65°C	65°C	77°C
Fuel consumption	3.2 kg	-	4.9 kg	6.9 kg	-
Connected load	4 kW (+2 frost protection)	1 kW (+2 frost protection)	3.2 kW	5.3 kW	5.6 kW + 24 kW
Power supply	3~/400 V/50 Hz	1~/230 V/50 Hz	1~/230 V/50 Hz	3~/400 V/50 Hz	3~/400 V/50 Hz

*Capacity osmosis system (RO): 100 l – Capacity water softening unit (BA) 65 °dH/m³ – Salt tank 35l – Permeate container 75l

Single and two-bay vacuums



	SB V1 Eco AC	Mono self-service vacuum AC	Mono self-service vacuum Three-phase current	Duo self-service vacuum AC	Duo self-service vacuum Three-phase current
Vacuum	230 mbar	180 mbar	210 mbar	180 mbar	210 mbar
Air flow rate	61 l/s	2 x 50 l/s	56 l/s	4 x 50 l/s	2 x 56 l/s
Container capacity	45 l	25 l	25 l	2 x 25 l	2 x 25 l
Connected load	1.38 kW	2 x 0.8 kW	1.5 kW	4 x 0.8 kW	2 x 1.5 kW
Power supply	1~/230 V/50 or 60 Hz	1~/230 V/50 or 60 Hz	3~/400 V/50 Hz	1~/230 V/50 or 60 Hz	3~/400 V/50 Hz

Varied offers: Kärcher washing bay equipment.

With Kärcher original accessories and special cleaning agents, your washing bay is well equipped. Kärcher constantly further develops its accessories to meet customer requirements in the future.



1 Optimal storage

The patented automatic alignment of the combination washing tool or foam brush parallel to the direction of travel ensures convenience and tidiness at washing bays.

2 Varied wash programmes

A self-explanatory control serves for easy wash programme selection. The system also features a remaining wash time display.

3 Attractive supplementary offers

With additional accessories such as the mat beater, washing bays can offer more.



- 1 Foam brush
- 2 Combination lance
- 3 High-pressure lance

Cleaning agents – tough on dirt, easy on the environment.

Product description	Use	Product information
Pre-spraying, high-pressure wash and foam wash		
 RM 803 ASF prewash Active, gentle high-pressure pre-spraying agent. Facilitates soaking and removal of oil and grease deposits as well as insects.	For hot water high-pressure cleaners, coin-op car washes, pre-spray units or brush car washes Primary mixture: 1+2 to 1+49 Dosage: 0.5–2 %	Alkaline pH: 13 in concentrate
 CP 930 ASF intensive dirt remover Active pre-spray agent, effortlessly removes stubborn grease and oil stains. It easily accelerates the soaking and removal of insect residues.	Used in coin-op car washes and high-pressure cleaners Dosage: 0.5 %	Alkaline pH: 13 in concentrate
 RM 806 ASF HP wash This concentrate has a broad dirt-dissolving range and removes the most stubborn road dirt, such as dust, oil, lubricating grease, insects, tree resin and mud. ²⁾	Principally used with hot water, high-pressure cleaners and in coin-op washes Primary mixture: 1+3 Dosage: 0.2–0.5 %	Alkaline pH: 13.3 in concentrate
 CP 935 ASF HP wash Highly effective cleaning concentrate with an apple scent for vehicle washes. Removes dust, oil, lubricants, insect residues, pitch and mud. ²⁾	Used in self-service washing installations and in high-pressure cleaners. Dosage: 0.3 %	Alkaline pH: 12.2 in concentrate
 RM 838 foam cleaner Brilliant results with brushless vehicle washing. Intensive foam cleaner with high dirt carrying capacity. Removes the most stubborn dirt, including insect residues, tar, soot, oil and grease. Fresh fruity aroma, no sodium triphosphate.	Principally used in automatic brush car washes Dosage: 0.2 %	Slightly alkaline pH: 8.7 in concentrate
 CP 940 ASF active foam Slightly alkaline cleaning shampoo, produces a stable foam in cleanpark® systems and coin-op car washes. CP 940 conserves the surface and can be easily rinsed away. It has a pleasantly fresh lemon scent. ²⁾	Used in coin-op car washes and high-pressure cleaners Dosage: 1.3 %	Slightly alkaline pH: 11.4 in concentrate
 RM 812 ASF active foam Very effective high-foam brush shampoo. Specially formulated to protect vehicle surfaces as well as the brushes. ²⁾	Used primarily in automatic brush car washes and coin-op car washes Dosage: 0.2 %	Slightly alkaline pH: 8.9 in concentrate
Care and protection; wheel rim cleaning		
 CP 945 thermo wax This thermo-wax concentrate produces a water-repellent, durable coating with a high-gloss effect. With a high natural carnauba wax content. ¹⁾	Used in coin-op car washes and in high-pressure cleaners. Dosage: 0.2 %	Neutral pH: 4.5 in concentrate
 CP 950 Top Care Fluid spray wax for preservation and long-term protection. Insensitive to water hardness, it generates a stable high-lustre film, allows water to be removed from large surfaces and dries without leaving streaks or spots. ¹⁾	Used in coin-op car washes and in high-pressure cleaners. Dosage: 0.02 %	Neutral pH: 3.5 in concentrate
 RM 820 hot wax This liquid hot wax produces a weather-resistant coating which protects vehicles against corrosion. Contains natural carnauba wax. ¹⁾	Mainly used in brush car washes and coin-op car washes without blow drying and in high-pressure cleaners. Primary mixture: 1+9 Dosage: 0.1–0.2 %	Slightly acidic pH: 6.3 in concentrate
 RM 821 spray wax This liquid spray wax gives vehicles a shine and long-term protection. Not affected by the water quality, provides spotless finish without blow drying. ¹⁾	Used in coin-op car washes and hot water high-pressure cleaners Primary mixture: 1+9 Dosage: 1–2 %	Slightly acidic pH: 4 in concentrate
 RM 801 alkaline wheel cleaner Special wheel cleaner for all coated light-metal and steel rims (not suitable for uncoated high-gloss special rims). Gentle action effectively removes the most stubborn dirt, such as road dust, baked-on brake dust, tyre dust and deposits of winter salt. Does not attack concrete floors or wheel troughs.	Mainly used in coin-op car washes and brush car washes as manually applied pre-spraying agent Primary mixture: 1+9 to 1+4	Alkaline pH: 13.5 in concentrate Usage: 5.0 ml per rim
 CP 901 alkaline wheel cleaner CP 901 is a highly effective rim cleaner for removing brake dust. RM 901 is manually pre-sprayed in brush car washes or applied by the spray unit in the car wash. CP 901 has a greenish-yellow colour for good visibility on wheel rims to prevent overdosage.	Mainly used in coin-op car washes and brush car washes as manually applied pre-spraying agent Primary mixture: 1+9	Alkaline pH: 13.5 in concentrate
Other products		
 RM 841 ASF washing bay and tile cleaner This acidic washing bay and tile cleaner concentrate quickly and efficiently removes scale, lime, grease, soap residue and traces of rust.	For manual basic and maintenance cleaning of washing bays Dosage: Base cleaning: 20–50 % Routine cleaning: 5–10 %	Acidic pH: 1 in concentrate

¹⁾ Conforms to VDA Class A ²⁾ Conforms to VDA Class B

Everything perfectly aligned: the Kärcher recipe for success.

From washing bay equipment with Kärcher original accessories to the special cleaning agents and the cleanpark® franchise concept – Kärcher impresses with innovative technology, the highest quality and customer-oriented service.



1 Washing bay equipment

The versatile washing bay equipment will meet your needs and the preferences of your customers.

2 Cleaning agents

The special cleaning agents from Kärcher are effective against dirt and simultaneously protect both equipment and the environment.

3 The cleanpark® franchise system

Benefit as a self-employed operator from the support of a strong and reputable brand. The cleanpark® operator concept is one of the most successful franchise systems throughout Germany.

4 Service

Kärcher quality meets the highest demands. Kärcher is available for assistance 24-hours a day and provides a fast and reliable spare parts delivery service.

Working together for success – the cleanpark® franchise system.

The cleanpark® concept combines the advantages of a strong brand with entrepreneurial freedom. In Germany, 220 franchisees already benefit from this successful partnership. If you are interested, please give your full details to the Kärcher customer adviser.



Benefits that can be seen.

The cleanpark® franchise systems offers many advantages: the most up-to-date technology ensures that the systems are always at the cutting edge. A variety of communication measures address your customers in a targeted way and guarantees a clear lead over the competition.

■ Best support

If you have any questions regarding management, partner system, advertising measures or equipment, simply contact us.

■ Regular exchange

The annual partner meeting serves as an opportunity for an exchange of experiences as well as an information event for management, advertising and system technology.

■ Comprehensive advertising support

Displays, campaign packages and national advertising campaigns will support you in winning customers.



High level of awareness

Benefit from the cleanpark® image, a high level of awareness and a positive image.



Fair conditions

We supply cleaning agents, spare and wearing parts, system accessories and advertising materials to fair conditions.



Complete trust

cleanpark® is a full member of the German Franchise Association (DFV) and an approved member of the DFV.



Competent support

You can constantly further your technical knowledge at regular technical training sessions.

A strong partnership.

As the world's largest supplier of cleaning system solutions, Kärcher has been offering top-class products and service for over 75 years. Kärcher is always ready to help with highly trained service employees globally: in over 190 countries and at over 36,000 sale points, Kärcher offers sound advice, an exceptional maintenance and sales service and fast repairs.



1 All investments under control

The best system is one that is perfectly tailored to your requirements. This is why you will be advised by specially trained Kärcher employees on which system solution best fits your investment plans.

2 The right solution for all requirements

Comprehensive advice is the basis of a successful business. In order to make success calculable, the entire process is made transparent: from the initial investment to follow-up investments in existing self-service systems.

3 Cost-efficient maintenance service

Excellent service begins with exceptional quality. This keeps maintenance intervals efficient. Thanks to our almost global service, available 24 hours a day, optimal operation of your systems is guaranteed.

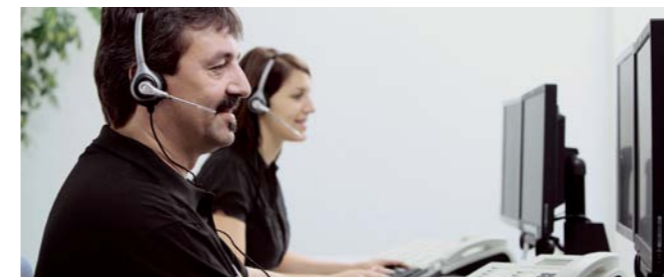

Friendly and expert support

The Kärcher service concept combines proven expertise in consulting, planning, design, development, technology and product management with an open ear for all of your concerns and therefore leads to results that set standards.

Please contact us for more information:**Head Office Germany**

Alfred Kärcher GmbH & Co. KG
Alfred-Kärcher-Straße 28-40
71364 Winnenden

Phone +49 7195-14-0
Fax +49 7195-14-2212
www.kaercher.com

North America

Kärcher North America
750 W. Hampden Avenue
Suite 400
Englewood, CO 80110
U.S.A.

Phone +001 303-738-2400
Fax +001 303-738-2818
www.karcherna.com

United Kingdom

Kärcher (UK) Ltd.
Kärcher House
Beaumont Road
Banbury
Oxon OX16 1TB

Phone +44 1295-752-100
Fax +44 1295-752-103
www.karcher.co.uk

Ireland

Kärcher Ltd.
C1 Centrepoint Business Park
Oak Road
Dublin 12

Phone +353 1-409-7777
Fax +353 1-409-7775
www.karcher.ie

Regional Head Office**Southeast Asia**

Kärcher South East Asia
Pte. Ltd.
5 Toh Guan Road East,
#01-00 Freight Links
Express Distripark,
Singapore 608831

Phone +65 68971811
Fax +65 68971611
www.karcher.com.sg

Hong Kong

Kärcher Ltd.
Unit 10, 17/F, APEC Plaza
49 Hoi Yuen Rd.,
Kwun Tong, KLN

Phone +852 2-357-5863
Fax +852 2-357-5632
www.karcher.com.hk

Australia

Kärcher Pty. Ltd.
40 Koornang Road
Scoresby VIC 3179
Melbourne, Victoria

Phone +61 3-9765-2300
Fax +61 3-9765-2399
www.karcher.com.au

New Zealand

Kärcher Ltd.
66 Allens Road
East Tamaki
Auckland

Phone +64 9-274-4603
Fax +64 9-274-6932
www.karcher.co.nz

South Africa

Kärcher Pty. Ltd.
144 Kuschke Street
Meadowdale
Edenvale
1614
South Africa

Phone +27 11-574-5360
Fax +27 11-454-4682
www.karcher.co.za

United Arab Emirates

Kärcher FZE
P.O. Box 17416
Plot No S-10104, South Zone
Jebel Ali Free Zone, Dubai

Phone +971 (0)4-886-1177
Fax +971 (0)4-886-1575
www.kaercher.com